

Decanter System

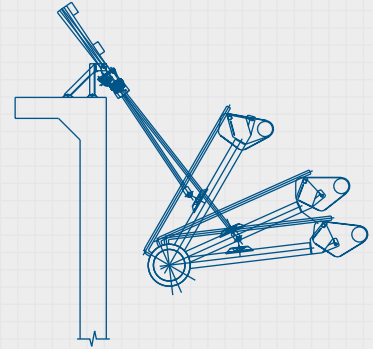

Sanitaire



ITT Industries
Engineered for life



Decanter System

Sanitaire has developed through years of experience, a high quality, advanced-engineered decanter.

- Rugged, corrosion resistant stainless steel construction.
- Uses an electromechanical actuator with redundant limit switches and variable frequency drives (VFDs) for speed control.
- Decants from the top down withdrawing only the uppermost clear water from the basin preventing disruption of the settling solids.
- Effluent flow is visible providing a quick check of effluent quality.
- Rests clear of liquid during aeration eliminating the need for valves that are subject to failure.
- Rests below the top of the basin wall acting as an emergency overflow device during power outages.
- Removes effluent from 2-3" below water surface level and excludes scum and other floatables.
- Visible and accessible from the walkway allowing easy access and service without the need to enter the basin.
- Constant overflow rate over entire length of decant period.
- Easy installation.



Contact Sanitaire for more information

9333 N. 49th Street
Brown Deer, WI 53223 USA
Tel 414 365 2200
Fax 414 365 2210
www.sanitaire.com

Sanitaire



ITT Industries
Engineered for life